

OFST 575-HZ

REFRIGERATING CAPACITY (kW)

Tc	Te	
	-30	-25
40	4,23	5,67
45	3,69	5,01
50	3,16	4,36

POWER CONSUMPTION (kW)

Tc	Te	
	-30	-25
40	3,24	3,84
45	3,22	3,86
50	3,18	3,85

Tc : Condensation temperature
Te : Evaporation temperature

Condenser

Condenser	
Compressor Model	TAG 2525 Z
Compressor Brand	Tecumseh
Compressor Type	Hermetic
Refrigerant	R404A
Voltage	380 V / 3 / 50 Hz

Chassis	
Chassis	TK 500-1021S/1x450
Fin Spacing	2,1 mm
Fan	1 x Ø 450 mm
Fan Brand	Embpapst
Consump. Capacity	490 Watt
Air Volume	4047,1 m ³ /h
Surface Area	33,89 m ²

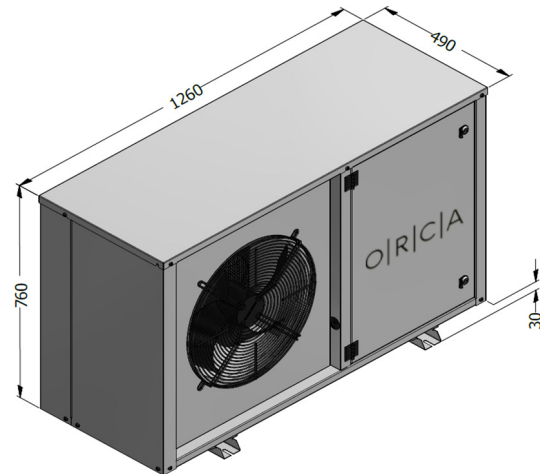

Evaporator

Evaporator	
Evaporator	ORE 40.21.8
Fin Spacing	8 mm
Defrost	E2 9 x 300 Watt
Expansion	TV
Fan	2 x Ø 400 mm
Fan Brand	Ebmpapst
Consump. Capacity	438 Watt
Air Volume	7380 m ³ /h
Surface Area	25.7 m ²
Number of Evap.	1

E : Electric
TV : Thermostatic valve

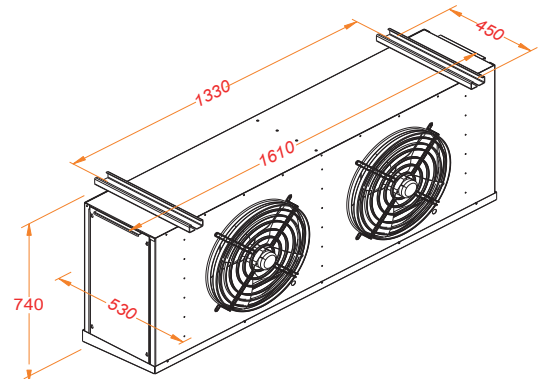

Pipe Diameters (inches)	
Suction Line	7/8"
Liquid Refrigerant Line	1/2"

P: +90 212 694 58 58
F: +90 212 694 58 59

info@tekop.com.tr

Gokevler Mah. 2245 Sok.
No:7 Holpark Sit.
Esenyurt/Istanbul/TURKEY