

OFST 360-HZ

REFRIGERATING CAPACITY (kW)

Tc	Te	
	-30	-25
40	2,85	3,97
45	2,42	3,44
50	2,00	2,92

POWER CONSUMPTION (kW)

Tc	Te	
	-30	-25
40	2,32	2,78
45	2,28	2,77
50	2,23	2,74

Tc : Condensation temperature
Te : Evaporation temperature

Condenser

Condenser	
Compressor Model	TAG 2516 Z
Compressor Brand	Tecumseh
Compressor Type	Hermetic
Refrigerant	R404A
Voltage	380 V / 3 / 50 Hz

Chassis	
Fin Spacing	TK 500"1021S"1x400
Fin Spacing	2,1 mm
Fan	1 x Ø 400 mm
Fan Brand	Embpapst
Consump. Capacity	219 Watt
Air Volume	3222 m ³ /h
Surface Area	33,89 m ²

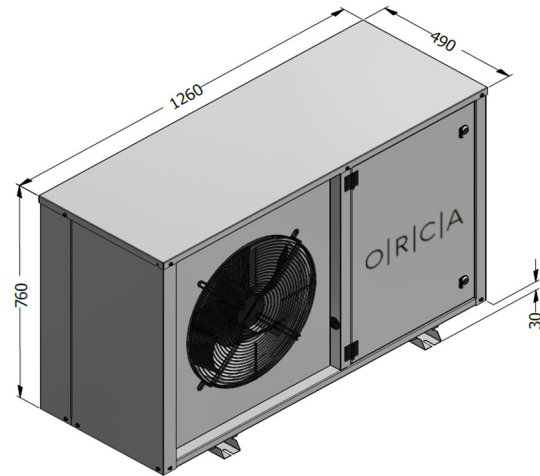

Evaporator

Evaporator	
Evaporator	ORE 30.32.6
Fin Spacing	6 mm
Defrost	E1 4 x 300 Watt
Expansion	TV
Fan	3 x Ø 300 mm
Fan Brand	Ebmpapst
Consump. Capacity	216 Watt
Air Volume	3140 m ³ /h
Surface Area	20,4 m ²
Number of Evap.	1

E : Electric
TV : Thermostatic valve

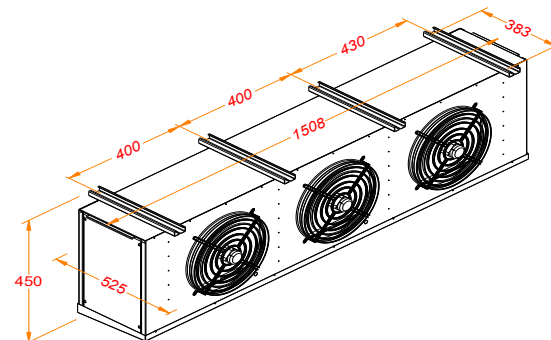

Pipe Diameters (inches)	
Suction Line	7/8"
Liquid Refrigerant Line	3/8"

P:+90 212 694 58 58
F:+90 212 694 58 59

info@tekop.com.tr

Gokevler Mah. 2245 Sok.
No:7 Holpark Sit.
Esenyurt/Istanbul/TURKEY