

OFST 270-HZ

REFRIGERATING CAPACITY (kW)

Tc	Te	
	-30	-25
40	2,41	3,30
45	2,08	2,91
50	1,76	2,51

POWER CONSUMPTION (kW)

Tc	Te	
	-30	-25
40	1,80	2,13
45	1,79	2,15
50	1,76	2,15

Tc : Condensation temperature
Te : Evaporation temperature

Condenser

Condenser	
Compressor Model	FH 2511 XG
Compressor Brand	Tecumseh
Compressor Type	Hermetic
Refrigerant	R404A
Voltage	380 V / 3 / 50 Hz

Chassis	TK 400"1021S"1x400
Fin Spacing	3,0 mm
Fan	1 x Ø 400 mm
Fan Brand	Embpapst
Consump. Capacity	219 Watt
Air Volume	2926,3 m ³ /h
Surface Area	10,43 m ²

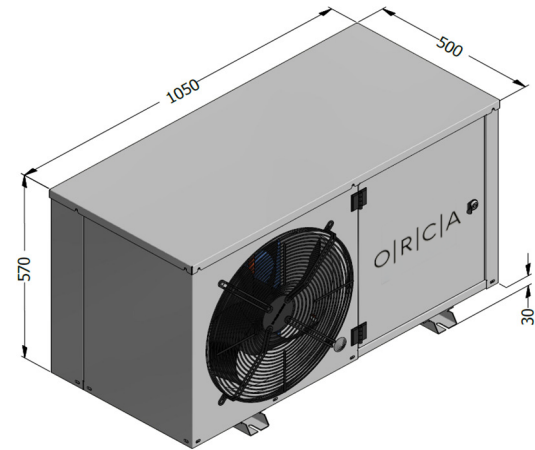

Evaporator

Evaporator	ORE 30.22.6
Fin Spacing	6 mm
Defrost	E1 4 x 200 Watt
Expansion	TV
Fan	2 x Ø 300 mm
Fan Brand	Ebmpapst
Consump. Capacity	144 Watt
Air Volume	2090 m ³ /h
Surface Area	13,6 m ²
Number of Evap.	1

E : Electric
TV : Thermostatic valve

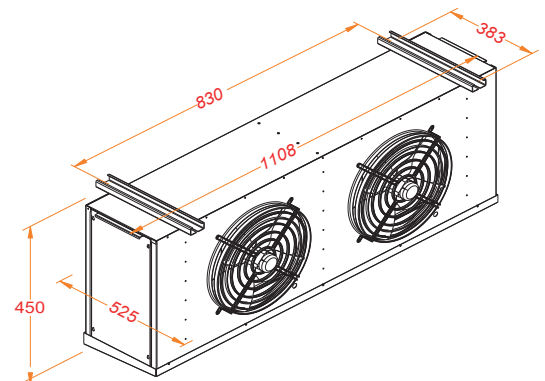

Pipe Diameters (inches)	
Suction Line	3/4"
Liquid Refrigerant Line	3/8"

P:+90 212 694 58 58
F:+90 212 694 58 59

info@tekop.com.tr

Gokevler Mah. 2245 Sok.
No:7 Holpark Sit.
Esenyurt/Istanbul/TURKEY