

OFST 170-HZ

REFRIGERATING CAPACITY (kW)

Tc	Te	
	-30	-25
40	1,72	2,35
45	1,48	2,07
50	1,25	1,79

POWER CONSUMPTION (kW)

Tc	Te	
	-30	-25
40	1,25	1,47
45	1,24	1,48
50	1,22	1,49

Tc : Condensation temperature
Te : Evaporation temperature

Condenser

Condenser	
Compressor Model	FH 2480 XG
Compressor Brand	Tecumseh
Compressor Type	Hermetic
Refrigerant	R404A
Voltage	380 V / 3 / 50 Hz

Chassis	
Chassis	TK 1B"1021S"1x300
Fin Spacing	2,5 mm
Fan	1 x Ø 350 mm
Fan Brand	Embpapst
Consump. Capacity	165 Watt
Air Volume	1769,7 m ³ /h
Surface Area	11,44 m ²

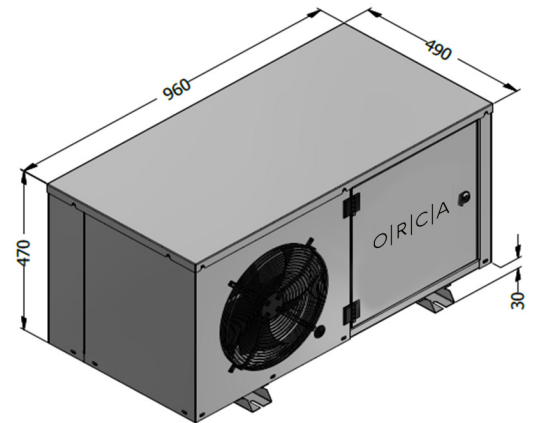

Evaporator

Evaporator	
Evaporator	ORE 30.21.6
Fin Spacing	6 mm
Defrost	E1 4 x 125 Watt
Expansion	TV
Fan	2 x Ø 300 mm
Fan Brand	Ebmpapst
Consump. Capacity	144 Watt
Air Volume	2330 m ³ /h
Surface Area	9,6 m ²
Number of Evap.	1

E : Electric
TV : Thermostatic valve

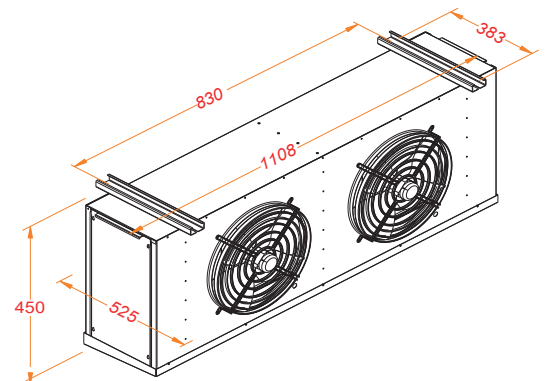

Pipe Diameters (inches)	
Suction Line	5/8"
Liquid Refrigerant Line	3/8"

P:+90 212 694 58 58
F:+90 212 694 58 59

info@tekop.com.tr

Gokevler Mah. 2245 Sok.
No:7 Holpark Sit.
Esenyurt/Istanbul/TURKEY