

OCST 500-HZ

REFRIGERATING CAPACITY (kW)

Tc	Te		
	-10	-5	0
40	4,20	5,26	6,47
45	3,74	4,70	5,80
50	3,28	4,14	5,12

POWER CONSUMPTION (kW)

Tc	Te		
	-10	-5	0
40	1,78	1,94	2,07
45	1,85	2,02	2,18
50	1,91	2,11	2,29

Tc : Condensation temperature
Te : Evaporation temperature

Condenser

Condenser	
Compressor Model	FH 4532 XG
Compressor Brand	Tecumseh
Compressor Type	Hermetic
Refrigerant	R404A
Voltage	380 V / 3 / 50 Hz

Chassis	
Chassis	TK 500"1021S"1x400
Fin Spacing	2,1 mm
Fan	1 x Ø 400 mm
Fan Brand	Embpapst
Consump. Capacity	219 Watt
Air Volume	3222 m ³ /h
Surface Area	33,89 m ²

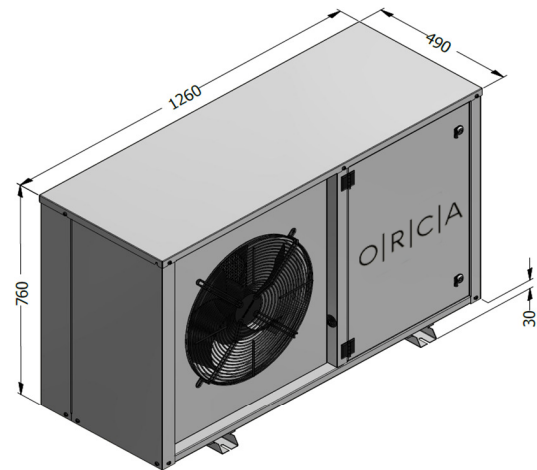

Evaporator

Evaporator	
Evaporator	ORE 30.31.6
Fin Spacing	6 mm
Defrost	E1 4 x 300 Watt
Expansion	TV
Fan	3 x Ø 300 mm
Fan Brand	Ebmpapst
Consump. Capacity	216 Watt
Air Volume	3500 m ³ /h
Surface Area	14,5 m ²
Number of Evap.	1

E : Electric
TV : Thermostatic valve

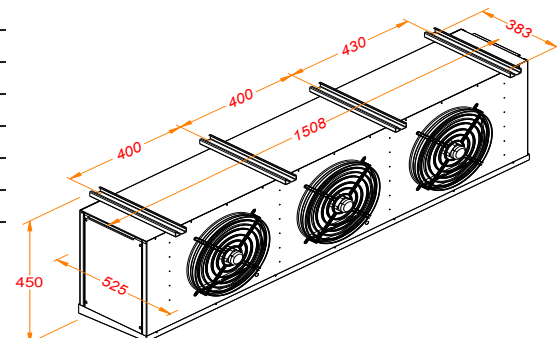

Pipe Diameters (inches)	
Suction Line	3/4"
Liquid Refrigerant Line	3/8"

P: +90 212 694 58 58
F: +90 212 694 58 59

info@tekop.com.tr

Gokevler Mah. 2245 Sok.
No:7 Holpark Sit.
Esenyurt/Istanbul/TURKEY